

GP Batteries

Data Sheet

Model No.: GP65AAAH

Type	Rechargeable Nickel Metal Hydride Cylindrical Cell	
Nominal Dimension (with Sleeve)	$\Phi = 10.5\text{mm}$	H = 43.7 mm
Applications	Recommended discharge current 65 to 1950mA	
Nominal Voltage	1.2V	
Capacity	Minimum: 650 mAh Typical: 680 mAh when discharged at 0.2C to 1.0V at 20°C	
Charging Condition	65 mA for 16 hrs at 20°C	
Fast Charge	325 mA to 650 mA (0.5 to 1C) charge termination control recommended control parameters: - ΔV : 0 - 5mV DT/dt ** : 0.8°C/min (0.5 to 0.9C) : 0.8 - 1°C/min (1C) TCO ** : 45 - 50°C Timer **: 105% nominal input ** For reference only	
Service Life	>500 cycles (IEC standard)	
Continuous Overcharge	65 mA maximum current for 1 year No conspicuous deformation and/or leakage	
Weight	13.0 g	
Internal Resistance	Average 35 m Ω upon fully charged (Range 20 – 50 m Ω) at 1000HZ	
Max. Charging Voltage	1.5V at 65 mA charging	
Ambient Temperature Range	Standard Charging	0 to 45°C
	Fast Charging	10 to 45°C
	Discharging	-20 to 50°C
	Storage	-20 to 35°C

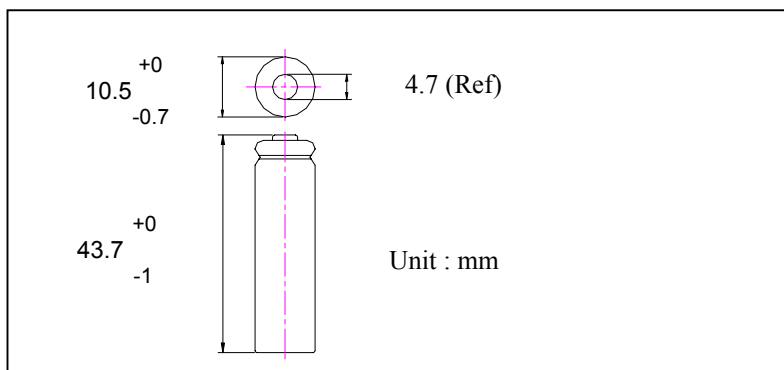

Fast Charge (charge control required)

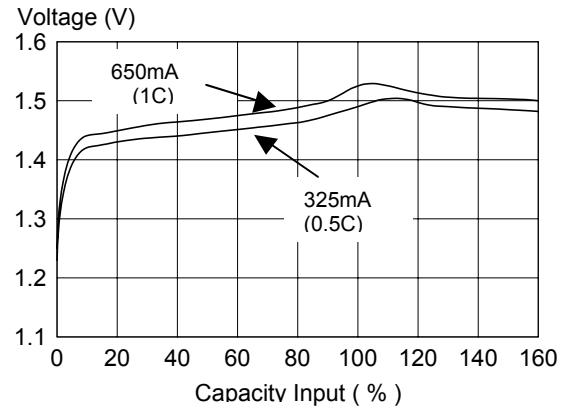

Low rate discharge

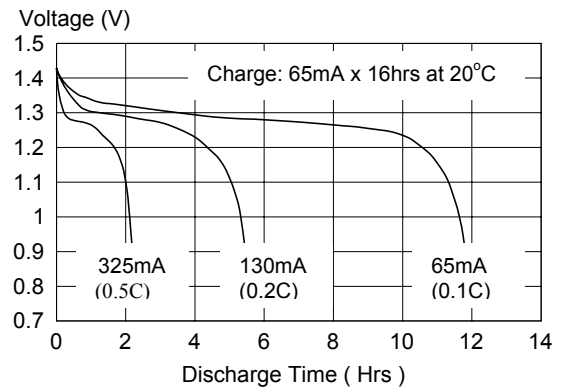

High Rate Discharge

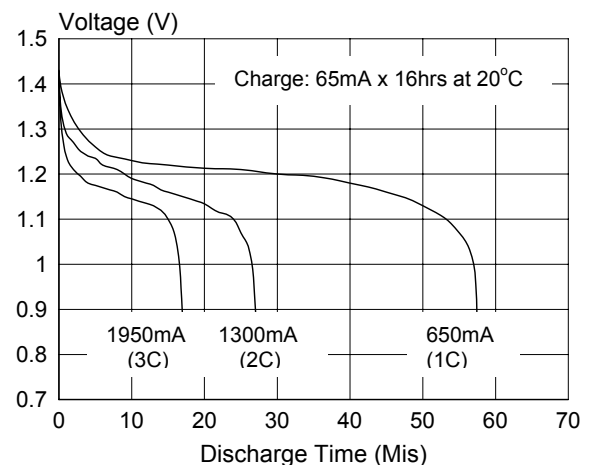

* The information (subject to change without prior notice) contained in this document is for reference only and should not be used as a basis for product guarantee or warranty. For applications other than those described here, please consult your nearest GP Sales and Marketing Office or Distributors.

